

- HIGH CROSSTALK ATTENUATION.
- VOICE & DATA TELECOM APPLICATIONS.
- FOR V.29 (9.6Kbps) MODEMS.
- DESIGNED FOR WET (90mA DC) CIRCUITS.
- HIPOT 1500Vrms.
- IMPEDANCE RATIO OF 600Ω : 600Ω.
- IDEAL FOR MULTIPLE RACK APPLICATIONS.
- LOW PROFILE (<.525"/13.34mm).
- UL RECOGNIZED COMPONENT - UL 1863, FILE E138250.
- ALTERNATE ECONOMY PART, SPT-195.

REVISIONS			
DATE	REV	DESCRIPTION	APP'V'D
09/24/93	-1	Changed THD specification, was specified in %	TJK
08/05/2015	-2	Updated drawing; added millimeter dimensions	TJK

Note : Pin Numbers are reference only. [] = mm
 This unit is symmetrical and can be rotated 180° without changing the pin-out or electrical performance.

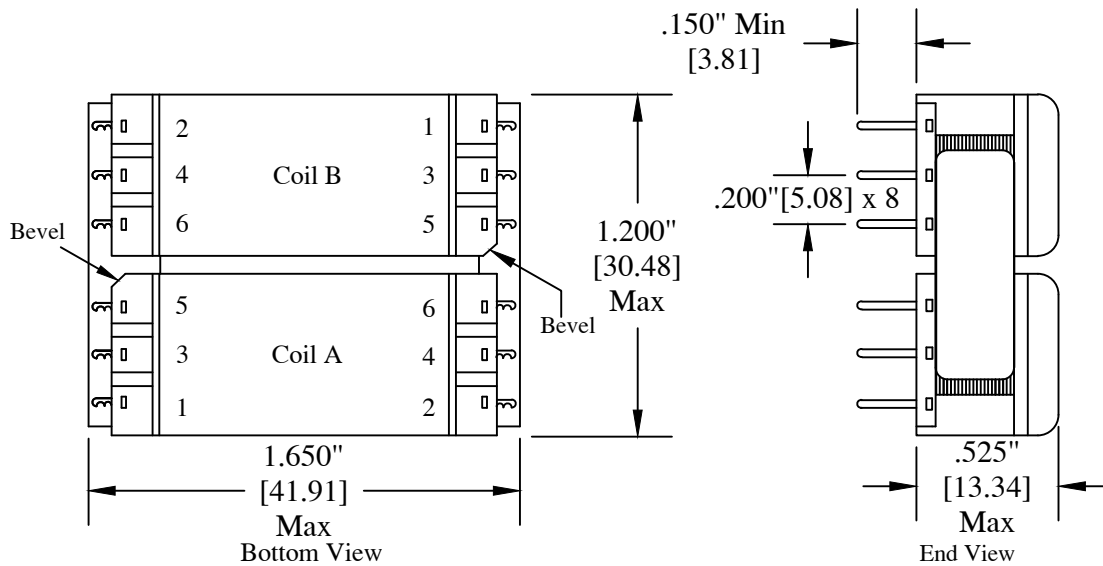

Electrical Parameters:

Primary Impedance : 600 Ω
 Secondary Impedance : 600 Ω
 Turns Ratio : 1:1 ±2%
 DC Resistance :
 Primary 95 Ω ±10% Total
 Secondary 180 Ω ±10% Total
 Max DC Current : 90 mAdc
 Frequency Range : 300-3500Hz
 Insertion Loss : 1.80B Max @ 1KHz
 Frequency Response : ±0.5dB, 1KHz Ref.
 Return Loss : 11.0 dB Min. @ 300Hz
 Longitudinal Balance : 60dB Min, per IEEE (connections:
 1A-2B with 2A-1B and 6A-5B tied and floating, 600Ω load
 with any secondary terminal grounded.
 Dielectric 1500Vrms : P-S-C instant
 THD @ 0dbm, 300Hz : -65dB typical
 Note : Reflected Z = 850 Ref. (Ohms)
 @ 1KHZ, 0mA D.C./Primary & 600Ohm RL/Secondary

All dimensions are reference unless otherwise specified.

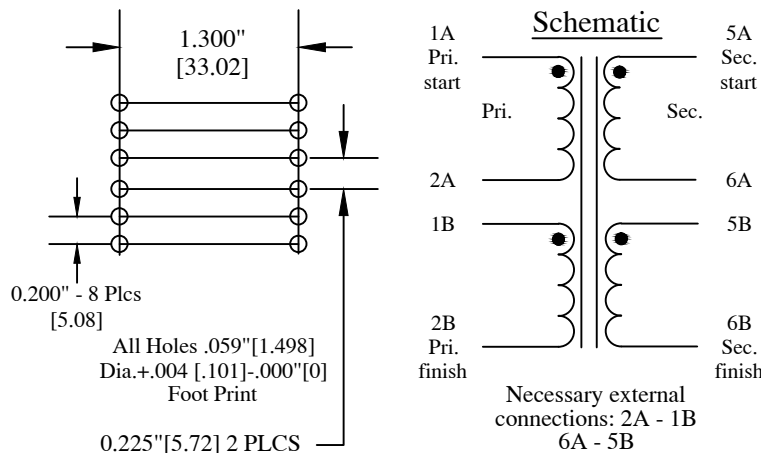

		CUSTOM ENGINEERING MAGNETIC COMPONENTS Johnsburg, Illinois 3521 N. Chapel Hill Rd. / McHenry, Illinois 60051	
		SCALE: None	APPROVED BY: <i>Tj Klotz</i>
DATE: 08-05-15	REVISIONS		REVISED
p/n SPT - 101			DRAWING NUMBER B-SPT-101-2